

Tentative Product Specification

Module name: BL043ACRNBS

Issue date: 2008/07/21

Version: 1.3

| | | |
|-----------------------------|---------------------|----------------|
| Customer | | |
| Approved by Customer | | |
| Approved by BOLYMIN | | |
| PD Division | ENG Division | QA Dept |
| | | |

Note:

1. The information contained herein may be change without prior notice. It is therefore advisable to contact BOLYMIN before designed your product based on this specification.
2. This tentative product specification is for reference, some item or setting maybe changed for evaluation.

Reversion History

| Version | Date | Page | Description |
|----------------|-------------|----------------------------|--|
| Ver.1.0 | 2007/12/26 | All | Tentative specification was first issued |
| Ver.1.1 | 2008/03/19 | 10,11,12 15,16,17 | Add IC Initial Register Setting Modify Pin Assignment |
| Ver.1.2 | 2008/04/08 | 18 10 14 19 20 | Change External Dimension Change Typical Luminance Add System Diagram Add Reliability Test Add Package Drawing |
| Ver.1.3 | 2008/07/21 | 9,10,11 | Modify Electro-Optical Characteristic |

1. Purpose:

This documentation defines general product specification for OLED module supplied by BOLYMIN. The information described in this technical specification is tentative. Please Contact BOLYMIN's representative while your product is modified.

2. General Description:

- Driving Mode: Active Matrix
- Color Mode: Full Color (16M color)
- Driver IC: HX5116, COG Assembly
- Interface:
8bit serial RGB and 24bit parallel RGB interface
- Application: Portable DVD, PMP, GPS, Photo Frame etc.

3. Mechanical Data:

| No. | Items | Specification | Unit |
|-----|---------------|-------------------|------|
| 1 | Diagonal Size | 4.3 | Inch |
| 2 | Resolution | 480 RGB x 272 | |
| 3 | Pixel Pitch | H: 0.198 V: 0.198 | um |
| 4 | Active Area | 95.0 x 53.8 | mm |
| 5 | Outline Area | 103.5 x 67 | mm |
| 6 | Thickness | 2.05 | mm |
| 7 | Weight | TBD | g |

4. Maximum ratings:

| Symbol | Parameter | Value | Unit |
|--------|-----------------------|--------------|------|
| VCC | Logic Supply Voltage | -0.3 to +3.6 | V |
| VCI | Analog Supply Voltage | -0.3 to +3.6 | V |
| Tstg | Storage Temperature | -40 to +85 | °C |

Table 7.1 Maximum ratings

Maximum ratings are those values beyond which damages to the device may occur. Functional operation should be restricted to the limits in the Electrical Characteristics tables or Pin Description section. Unused outputs must be left open.

5. Electrical Characteristic:

5.1 DC Characteristic

DC Characteristics

(Unless otherwise specified, Voltage Referenced to VSS = 0V, VCC = 1.5 to 3.6V, TA = -20 to 70C)

| Parameter | Symbol | Test condition | Min. | Typ. | Max. | Unit |
|---|----------|--------------------------------|-----------|------|-----------|------|
| System power supply pins of the logic block | VCC | - | 1.5 | - | 3.6 | V |
| Booster Reference Supply Voltage Range | VCI | - | 3.0 | - | 3.6 | V |
| DDVDH Output Voltage 1 | DDVDH | Set CP1X=0 | 4.9 | 5.1 | 5.3 | V |
| DDVDH Output Voltage 2 | DDVDH | Set CP1X=1 | 5.8 | 6.0 | 6.2 | V |
| VGAM1OUT Output Voltage 1 | VGAM1OUT | Set CP1X=0 | 4.7 | 4.8 | 4.9 | V |
| VGAM1OUT Output Voltage 2 | VGAM1OUT | Set CP1X=1 | 5.7 | 5.8 | 5.9 | V |
| Gate driver High Output Voltage | VGH | - | +3 | - | +8 | V |
| Gate driver Low Output Voltage | VGL | - | -8 | - | -3 | V |
| OLED Diode Refer Voltage | ARREF | - | -8 | - | +8 | V |
| Logic High Output Voltage | VOH | Iout=-400μA | 0.8 * VCC | - | VCC | V |
| Logic Low Output Voltage | VOL | Iout=400μA | 0 | - | 0.2 * VCC | V |
| Logic High Input voltage | VIH | - | 0.8 * VCC | - | VCC | V |
| Logic Low Input voltage | VIL | | 0 | - | 0.2 * VCC | V |
| Logic Input Current | IIL/IIH | No pull up or pull low | -1 | - | 1 | μA |
| Pull high resistance | RH | Pull up pins | 600 | 900 | 1200 | KΩ |
| Pull low resistance | RL | Pull low pins | 600 | 900 | 1200 | KΩ |
| High Output Current | IOH | S1~S107, Vo=4.9V vs. 4V | 50 | - | - | μA |
| Low Output Current | IOL | S1~S107, Vo=0.1V vs. 1V | - | - | -50 | μA |
| Output leakage Current | IOZ | - | -1 | - | 1 | μA |
| Output voltage offset | VOS | S1~S107, Vo=0.1V~DDVDH-0.1V | | ±10 | | mV |
| Output voltage deviation | VOD | S1~S107, Vo=0.1V~DDVDH-0.1V | | ±10 | | mV |
| Analog standby current | ISTB | VCI=3.0V, Stand by mode | | - | 10 | uA |
| Analog operating current | IVCI | VCI=3.0V, S1~S160 no load | | - | 20 | mA |
| Logic Pins Input Capacitance | CIN | - | - | 5 | 7.5 | pF |

5.2 AC Characteristic

5.2.1 AC Electrical Characteristics

| PARAMETER | Symbol | Min. | Typ. | Max. | Unit |
|--|-------------|------|------|------|-----------|
| HSYNC setup time | T_{ht} | 10 | - | - | ns |
| HSYNC hold time | T_{hhd} | 10 | - | - | ns |
| VSYNC setup time | T_{vat} | 10 | - | - | ns |
| VSYNC hold time | T_{vhd} | 10 | - | - | ns |
| Data setup time | T_{dsu} | 10 | - | - | ns |
| Data hold time | T_{dhd} | 10 | - | - | ns |
| DE setup time | T_{esu} | 10 | - | - | ns |
| VSYNC falling to HSYNC falling time on odd field @ RGB mode | T_{HV_O} | -4 | 0 | +4 | T_{CPH} |
| VSYNC falling to HSYNC falling time on even field @ RGB mode | T_{HV_E} | 0.4 | 0.5 | 0.6 | T_H |
| Source output settling time | T_{ST} | - | 3 | - | μs |
| Source output loading R | R_{SL} | - | 25 | - | K ohm |
| Source output loading C | C_{SL} | - | 16 | - | pF |
| Gate signals settling time (90%) | T_{GL} | - | 0.5 | - | μs |
| Gate signals loading R | R_{GL} | - | 5.6 | - | K ohm |
| Gate signals loading C | C_{GL} | - | 30 | - | pF |
| SW signals settling time (90%) | T_{SW} | - | 0.6 | - | μs |
| SW signals loading R | R_{SW} | - | 1.4 | - | K ohm |
| SW signals loading C | C_{SW} | - | 85.5 | - | pF |

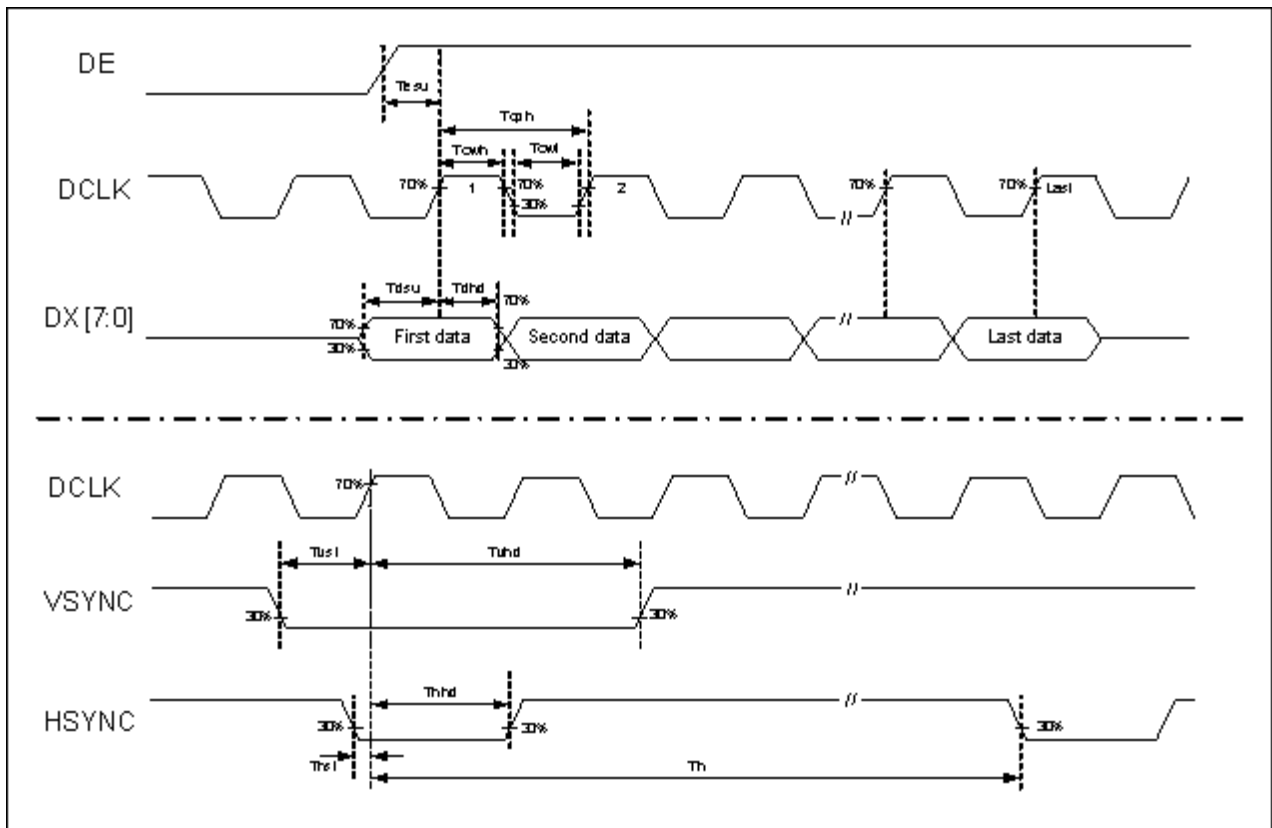

Clock and Data input waveforms

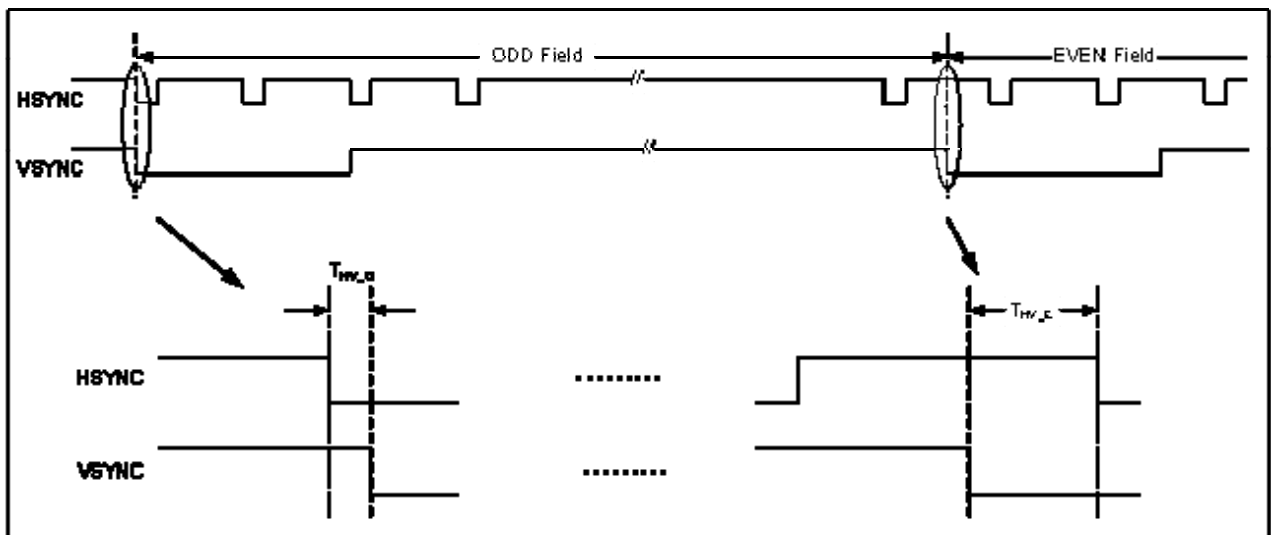

Define the HSYNC to VSYNC timing for RGB mode

5.2.2 480RGB X 272 serial RGB interface

| PARAMETER | Symbol | Min. | Typ. | Max. | Unit |
|--|-----------|------|------|------|-----------|
| DCLK frequency | F_{CPH} | 33.3 | - | - | MHz |
| DCLK period | T_{CPH} | - | - | 30 | ns |
| DCLK pulse duty | T_{CWH} | 40 | 50 | 60 | % |
| HSYNC period | T_H | - | 1836 | - | T_{CPH} |
| HSYNC pulse width | T_{WH} | 5 | 90 | - | T_{CPH} |
| HSYNC-first horizontal data time | T_{HBP} | 274 | 306 | 337 | T_{CPH} |
| DE pulse width | T_{EP} | - | 1440 | - | T_{CPH} |
| VSYNC pulse width | T_{WV} | 1 | 3 | 5 | T_H |
| VSYNC-1 st Data input (DE) time | T_{VBP} | 4 | 20 | 35 | T_H |
| VSYNC period | T_V | 302 | - | - | T_H |

5.2.2 480RGB X 272 parallel RGB interface

| PARAMETER | Symbol | Min. | Typ. | Max. | Unit |
|--|-----------|------|------|------|-----------|
| DCLK frequency | F_{CPH} | 11.1 | - | - | MHz |
| DCLK period | T_{CPH} | - | - | 90 | ns |
| DCLK pulse duty | T_{CWH} | 40 | 50 | 60 | % |
| HSYNC period | T_H | - | 612 | - | T_{CPH} |
| HSYNC pulse width | T_{WH} | 5 | 30 | - | T_{CPH} |
| HSYNC-first horizontal data time | T_{HBP} | 70 | 102 | 133 | T_{CPH} |
| DE pulse width | T_{EP} | - | 480 | - | T_{CPH} |
| VSYNC pulse width | T_{WV} | 1 | 3 | 5 | T_H |
| VSYNC-1 st Data input (DE) time | T_{VBP} | 4 | 20 | 35 | T_H |
| VSYNC period | T_V | 302 | - | - | T_H |

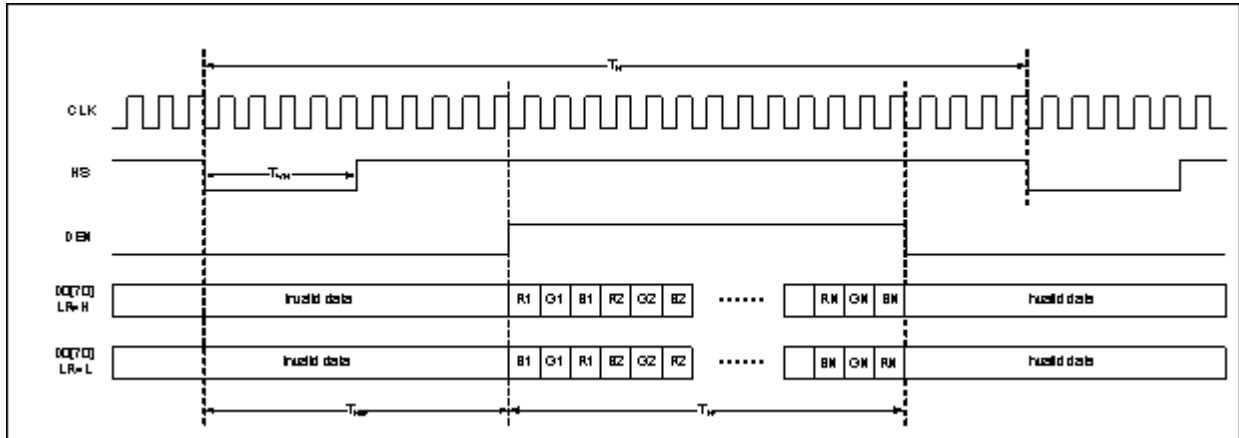
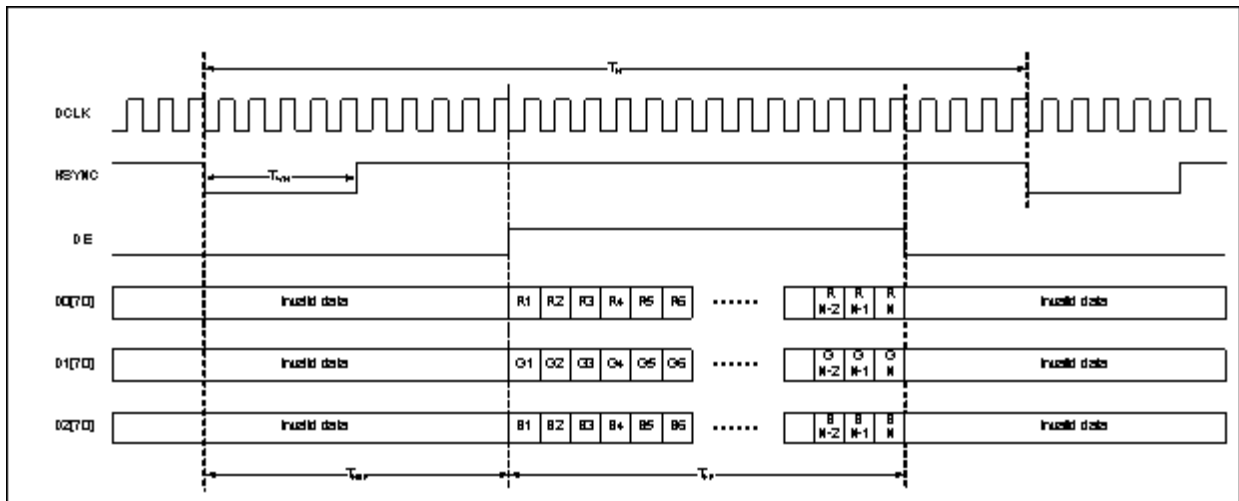
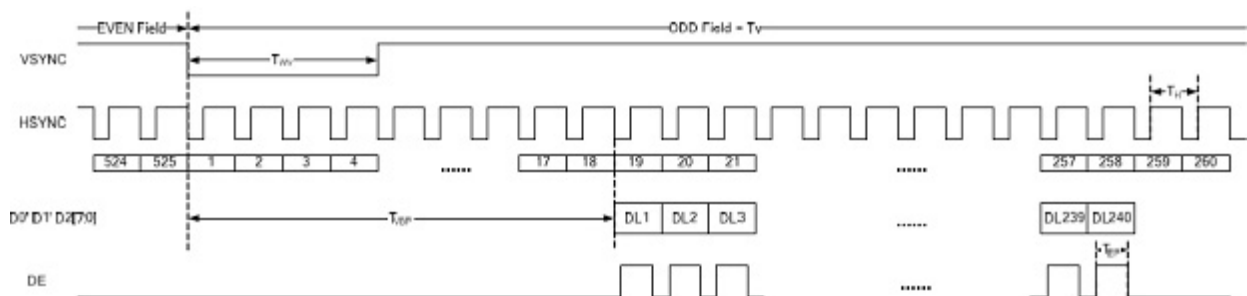
Serial RGB Horizontal Data Format

Parallel RGB Horizontal Data Format

Digital RGB Vertical Data Format

6. Electro-Optical Characteristic:

| Items | Symbol | Min | Typ. | Max | Unit | Remark |
|--------------------------|----------------|--------|---------|------|-------------------|-------------------|
| Operating Luminance | L | 170 | 200 | 230 | Cd/m ² | (1)(5) |
| Power Consumption | Pon | | 700 | 950 | mW | 30% pixels on (1) |
| Maximum Current | Icc | | 220 | 302 | mA | (1) |
| Response Time | Tres | | | 50 | uS | (2) |
| CIE _x (White) | W _x | 0.26 | 0.31 | 0.36 | - | (5) |
| CIE _y (White) | W _y | 0.28 | 0.33 | 0.38 | - | (5) |
| CIE _x (Red) | R _x | 0.62 | 0.66 | 0.70 | - | (5) |
| CIE _y (Red) | R _y | 0.30 | 0.34 | 0.38 | - | (5) |
| CIE _x (Green) | G _x | 0.25 | 0.29 | 0.33 | - | (5) |
| CIE _y (Green) | G _y | 0.62 | 0.66 | 0.70 | - | (5) |
| CIE _x (Blue) | B _x | 0.11 | 0.15 | 0.19 | - | (5) |
| CIE _y (Blue) | B _y | 0.12 | 0.16 | 0.20 | - | (5) |
| Viewing Angle | VA | 160 | 170 | | Degree | (3) |
| Contrast | CR | 5000:1 | 10000:1 | | | (4) |
| Operation Lifetime | LTop | 20000 | | | Hrs | (1)(6) |

Note:

Measuring surrounding: dark room

Surrounding temperature: 25°C

1. Test condition:

a. AR_VDD= 5.2V +/-0.03V, AR_VSS= -4.8V +/-0.03V

b. IC Initial Register Setting:

| 24-bit parallel RGB (DE) | |
|--------------------------|--|
| Index_out(0x04); | Parameter_out(0x23); //set display mode 24-bit parallel RGB (DE) |
| Index_out(0x05); | Parameter_out(0x82); //set display mode |
| Index_out(0x07); | Parameter_out(0x0F); //set driver capability |
| Index_out(0x34); | Parameter_out(0x18); //set display timing |
| Index_out(0x35); | Parameter_out(0x28); //set display timing |
| Index_out(0x36); | Parameter_out(0x16); //set display timing |
| Index_out(0x37); | Parameter_out(0x01); //set display timing |
| Index_out(0x02); | Parameter_out(0x02); //OTP On |
| Index_out(0x0A); | Parameter_out(0x79); //VGHVGL=+/-6V |

| | |
|------------------|---------------------------------------|
| Index_out(0x09); | Parameter_out(0x26); //VGAM1OUT=5.0V |
| Index_out(0x10); | Parameter_out(0x07); //set R slop |
| Index_out(0x11); | Parameter_out(0x08); //set G slop |
| Index_out(0x12); | Parameter_out(0x07); //set B slop |
| Index_out(0x13); | Parameter_out(0x00); //set R_0 |
| Index_out(0x14); | Parameter_out(0x01); //set R_10 |
| Index_out(0x15); | Parameter_out(0x02); //set R_36 |
| Index_out(0x16); | Parameter_out(0x01); //set R_80 |
| Index_out(0x17); | Parameter_out(0x02); //set R_124 |
| Index_out(0x18); | Parameter_out(0x02); //set R_168 |
| Index_out(0x19); | Parameter_out(0x03); //set R_212 |
| Index_out(0x1A); | Parameter_out(0x06); //set R_255 |
| Index_out(0x1B); | Parameter_out(0x00); //set G_0 |
| Index_out(0x1C); | Parameter_out(0x02); //set G_10 |
| Index_out(0x1D); | Parameter_out(0x00); //set G_36 |
| Index_out(0x1E); | Parameter_out(0x01); //set G_80 |
| Index_out(0x1F); | Parameter_out(0x02); //set G_124 |
| Index_out(0x20); | Parameter_out(0x03); //set G_168 |
| Index_out(0x21); | Parameter_out(0x03); //set G_212 |
| Index_out(0x22); | Parameter_out(0x05); //set G_255 |
| Index_out(0x23); | Parameter_out(0x00); //set G_0 |
| Index_out(0x24); | Parameter_out(0x03); //set B_10 |
| Index_out(0x25); | Parameter_out(0x06); //set B_36 |
| Index_out(0x26); | Parameter_out(0x07); //set B_80 |
| Index_out(0x27); | Parameter_out(0x06); //set B_124 |
| Index_out(0x28); | Parameter_out(0x05); //set B_168 |
| Index_out(0x29); | Parameter_out(0x05); //set B_212 |
| Index_out(0x2A); | Parameter_out(0x08); //set B_255 |
| Index_out(0x06); | Parameter_out(0x03); //set display on |
| AR_VDD= +5.2V | |
| AR_VSS= -4.8V | |

| | |
|------------------------------|---|
| 8-bit serial RGB (DE) | |
| Index_out(0x04); | Parameter_out(0x21); //set display mode 8-bit serial RGB (DE) |
| Index_out(0x05); | Parameter_out(0x82); //set display mode |
| Index_out(0x07); | Parameter_out(0x0F); //set driver capability |
| Index_out(0x34); | Parameter_out(0x48); //set display timing |
| Index_out(0x35); | Parameter_out(0x78); //set display timing |

| | |
|------------------|---|
| Index_out(0x36); | Parameter_out(0x42); //set display timing |
| Index_out(0x37); | Parameter_out(0x01); //set display timing |
| Index_out(0x02); | Parameter_out(0x02); //OTP On |
| Index_out(0x0A); | Parameter_out(0x79); //VGHVGL=+/-6V |
| Index_out(0x09); | Parameter_out(0x26); //VGAM1OUT=5.0V |
| Index_out(0x10); | Parameter_out(0x07); //set R slop |
| Index_out(0x11); | Parameter_out(0x08); //set G slop |
| Index_out(0x12); | Parameter_out(0x07); //set B slop |
| Index_out(0x13); | Parameter_out(0x00); //set R_0 |
| Index_out(0x14); | Parameter_out(0x01); //set R_10 |
| Index_out(0x15); | Parameter_out(0x02); //set R_36 |
| Index_out(0x16); | Parameter_out(0x01); //set R_80 |
| Index_out(0x17); | Parameter_out(0x02); //set R_124 |
| Index_out(0x18); | Parameter_out(0x02); //set R_168 |
| Index_out(0x19); | Parameter_out(0x03); //set R_212 |
| Index_out(0x1A); | Parameter_out(0x06); //set R_255 |
| Index_out(0x1B); | Parameter_out(0x00); //set G_0 |
| Index_out(0x1C); | Parameter_out(0x02); //set G_10 |
| Index_out(0x1D); | Parameter_out(0x00); //set G_36 |
| Index_out(0x1E); | Parameter_out(0x01); //set G_80 |
| Index_out(0x1F); | Parameter_out(0x02); //set G_124 |
| Index_out(0x20); | Parameter_out(0x03); //set G_168 |
| Index_out(0x21); | Parameter_out(0x03); //set G_212 |
| Index_out(0x22); | Parameter_out(0x05); //set G_255 |
| Index_out(0x23); | Parameter_out(0x00); //set G_0 |
| Index_out(0x24); | Parameter_out(0x03); //set B_10 |
| Index_out(0x25); | Parameter_out(0x06); //set B_36 |
| Index_out(0x26); | Parameter_out(0x07); //set B_80 |
| Index_out(0x27); | Parameter_out(0x06); //set B_124 |
| Index_out(0x28); | Parameter_out(0x05); //set B_168 |
| Index_out(0x29); | Parameter_out(0x05); //set B_212 |
| Index_out(0x2A); | Parameter_out(0x08); //set B_255 |
| Index_out(0x06); | Parameter_out(0x03); //set display on |
| AR_VDD= +5.2V | |
| AR_VSS= -4.8V | |

2. Response Time test condition

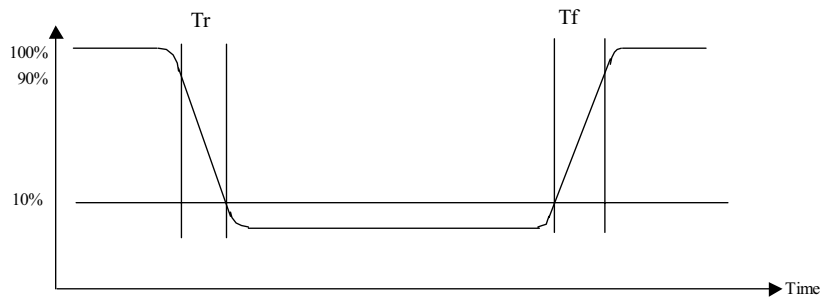

3. Viewing angle test condition:

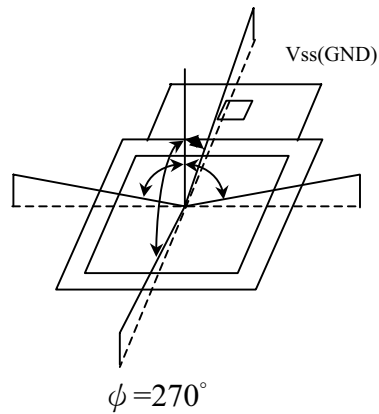

4. Contrast

$$CR = \frac{\text{Luminance with all pixels white}}{\text{Luminance with all pixels black}}$$

5. Optical tester: CA210

6. Brightness of 30% power consumption. Operating Life Time is defined when the luminance has decayed to less than 50% of the initial measured luminance before life test.

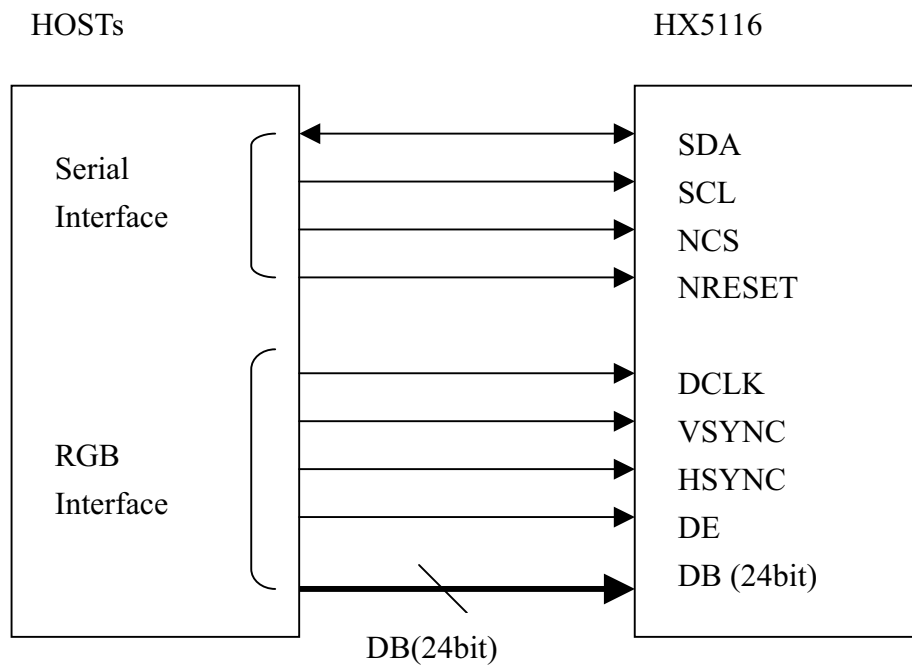
7. System Diagram:

8. Pin Assignment:

| PIN | Symbol | I/O | Description | Remarks | | | |
|------|----------|----------------|--|---------|------|--------|---|
| 1 | TP1 | I | Touch panel P1 | | | | |
| 2 | TP2 | I | Touch panel P2 | | | | |
| 3 | TP3 | I | Touch panel P3. | | | | |
| 4 | TP4 | I | Touch panel P4 | | | | |
| 5 | AR_VSS | I | Negative voltage for OLED | | | | |
| 6 | AR_VSS | I | Negative voltage for OLED | | | | |
| 7 | TEST1_VS | open | Test pin, it must be open. | | | | |
| 8 | AR_VDD | I | Positive voltage for OLED | | | | |
| 9 | AR_VDD | I | Positive voltage for OLED | | | | |
| 10 | TEST2_VD | open | Test pin, it must be open. | | | | |
| 11 | ARREF | I/O | Panel refers voltage of the regulator ARREF or external input voltage. (-8V~+8V) | | | | |
| 12 | VGL | I/O | Low Voltage output of regulator VGL or external input voltage. (-3V~-8V) | | | | |
| 13 | VGH | I/O | High Voltage output of regulator VGH or external input voltage. (+3V~+8V) | | | | |
| 14 | LVO | I/O | Negative output voltage of the booster2. (-8.5V) | | | | |
| 15 | C22N | I/O | Connect to the step-up circuit, capacitors according to the step-up factor. Leave this pin open if the internal step-up circuit is not used. | | | | |
| 16 | C22P | | | | | | |
| 17 | HVO | I/O | Positive output voltage of the booster2. (8.5V) | | | | |
| 18 | C21P | I/O | Connect to the step-up circuit, capacitors according to the step-up factor. Leave this pin open if the internal step-up circuit is not used. | | | | |
| 19 | C21N | | | | | | |
| 20 | C11N | I/O | Connect to the step-up circuit, 4capacitors according to the step-up factor. Leave this pin open if the internal step-up circuit is not used. | | | | |
| 21 | C11P | | | | | | |
| 22 | C12N | | | | | | |
| 23 | C12P | | | | | | |
| 24 | PVSS | P | Charge pump ground pin, it must connect to external ground. | | | | |
| 25 | DDVDH | I/O | Output voltage of the booster1. (5.1V/6.0V) | | | | |
| 26 | VSSA | P | Analog ground pin. It must connect to external ground. | | | | |
| 27 | VSSA | P | Analog ground pin. It must connect to external ground. | | | | |
| 28 | VCI | P | A power supply for the Analog circuit. (3.0V~3.6V) | | | | |
| 29 | VCI | P | A power supply for the Analog circuit. (3.0V~3.6V) | | | | |
| 30 | VGAM1OUT | I/O | Output voltage of the VGAM1OUT regulator and used positive power of source driver. (4.8V/5.8V) | | | | |
| 31 | VDDD | I/O | Internal logic voltage input or output pin | | | | |
| | | | VDC_ENB=0, VDDD is output, please connect to 1uF capacitor. | | | | |
| | | | <table border="1"> <thead> <tr> <th>VDC0</th> <th>VDDD</th> <th>Status</th> </tr> </thead> <tbody> <tr> <td>0</td> <td>1.8V</td> <td>Normal display</td> </tr> </tbody> </table> | VDC0 | VDDD | Status | 0 |
| VDC0 | VDDD | Status | | | | | |
| 0 | 1.8V | Normal display | | | | | |

| | | <table border="1" style="display: inline-table; vertical-align: middle;"> <tr> <td style="width: 30px; text-align: center;">1</td> <td style="width: 30px; text-align: center;">2.5V</td> <td style="width: 30px; text-align: center;">OTP program</td> </tr> </table> | | | 1 | 2.5V | OTP program | |
|-----------|--------|--|---|--|---|------|-------------|--|
| 1 | 2.5V | OTP program | | | | | | |
| | | VDC_ENB=1, VDDD is input. (Input range = 1.6V~2.75V) | | | | | | |
| 32 | VCC | P | A power supply for the Digital circuit. (1.5V~3.6V) | | | | | |
| 33 | VSSD | P | Digital ground pin. It must connect to external ground. | | | | | |
| 34 | NRESET | I | Reset pin. Setting either pin low initializes the LSI. Must be reset after power is supplied. (Normally pull high) | | | | | |
| 35 | NCS | I | Serial Interface chip enable pin. (Normally pull high) | | | | | |
| 36 | SCL | I | Serial Interface clock input pin. (Normally pull high) | | | | | |
| 37 | SDA | I | Serial Interface data line. (Normally pull high) | | | | | |
| 38 | DE | I | Data enable: When VSYNC+HSYNC+DE mode, DE=H: Data enable, DE=L: Data disable (Black). (Normally pull low) | | | | | |
| 39 | VSYNC | I | Frame synchronizing signal. If VSPL=0: Active low. If VSPL=1: Active high. | | | | | |
| 40 | HSYNC | I | Line synchronizing signal. If HSPL=0: Active low. If HSPL=1: Active high. | | | | | |
| 41 | DCLK | I | Dot clock signal. If DPL=0: Data are input on the rising edge of DOTCLK. If DPL=1: Data are input on the falling edge of DOTCLK. | | | | | |
| 42 | D27 | I | Digital data input. DX0 is LSB and DX7 is MSB. (Normally pull low) 1. If parallel RGB input mode is used, D0X, D1X, and D2X indicate R, G, and B data in turn. 2. If serial RGB or RGBD or CCIR601 or CCIR656 input mode is selected, only D07~D00 are used, and others short to GND. DX7~DX0 has 8-bit width, respectively to compose 16,777,216 color and 256 gray scale of 1 pixel. | | | | | |
| 43 | D26 | | | | | | | |
| 44 | D25 | | | | | | | |
| 45 | D24 | | | | | | | |
| 46 | D23 | | | | | | | |
| 47 | D22 | | | | | | | |
| 48 | D21 | | | | | | | |
| 49 | D20 | | | | | | | |
| 50 | D17 | | | | | | | |
| 51 | D16 | | | | | | | |
| 52 | D15 | | | | | | | |
| 53 | D14 | | | | | | | |
| 54 | D13 | | | | | | | |
| 55 | D12 | | | | | | | |
| 56 | D11 | | | | | | | |
| 57 | D10 | | | | | | | |
| 58 | D07 | | | | | | | |
| 59 | D06 | | | | | | | |

| | | | | |
|-----------|----------------|-------------|-----------------------------------|--|
| 60 | D05 | | | |
| 61 | D04 | | | |
| 62 | D03 | | | |
| 63 | D02 | | | |
| 64 | D01 | | | |
| 65 | D00 | | | |
| 66 | TEST3_W | open | Test pin, it must be open. | |
| 67 | AR_VDD | I | Positive voltage for OLED | |
| 68 | AR_VDD | I | Positive voltage for OLED | |
| 69 | AR_VSS | I | Negative voltage for OLED | |
| 70 | AR_VSS | I | Negative voltage for OLED | |
| 71 | TEST4_P | open | Test pin, it must be open. | |

10. Reliability Test:

| No | Item | Specification |
|----|---------------------------------|--|
| 1 | High Temp. Storage | 85°C, 240hr |
| 2 | Low Temp. Storage | -40°C, 240hr |
| 3 | High Temp. Operation | 60°C, 240hr |
| 4 | Low Temp. Operation | -40°C, 240hr |
| 5 | High Temp./ High Hum. Storage | 85°C, 85 % RH, 120 hr |
| 6 | High Temp./ High Hum. Operation | 60°C, 90 % RH, 240hr |
| 7 | Thermal Shock storage | -40°C, 30 min. --> 85°C, 30 min., 100 cycles |
| 8 | ESD | (1) Contact discharge mode: +/- 2kV, 3 times/FPC pin (2) Air discharge mode: +/- 8 kV, 10 times/central area |
| 9 | Packing Test | Drop 1 corner, 3 sides, 6 faces, 1 time for each; Height: follow ISTA standard. Frequency: 5~50HZ, 0.5G Scan rate: 1 oct/min Time: 2 hrs/axis Test axis: X, Y, Z |

Evaluation Criteria

- No damage to glass or encapsulation
- No drastic change to display
- Defects / Mura follow product specification
- Luminance: Within +/-50% of initial value
- Current consumption: within +/-50% of initial value