

WG192128A Graphic 192x128 dots

Dimension drawing

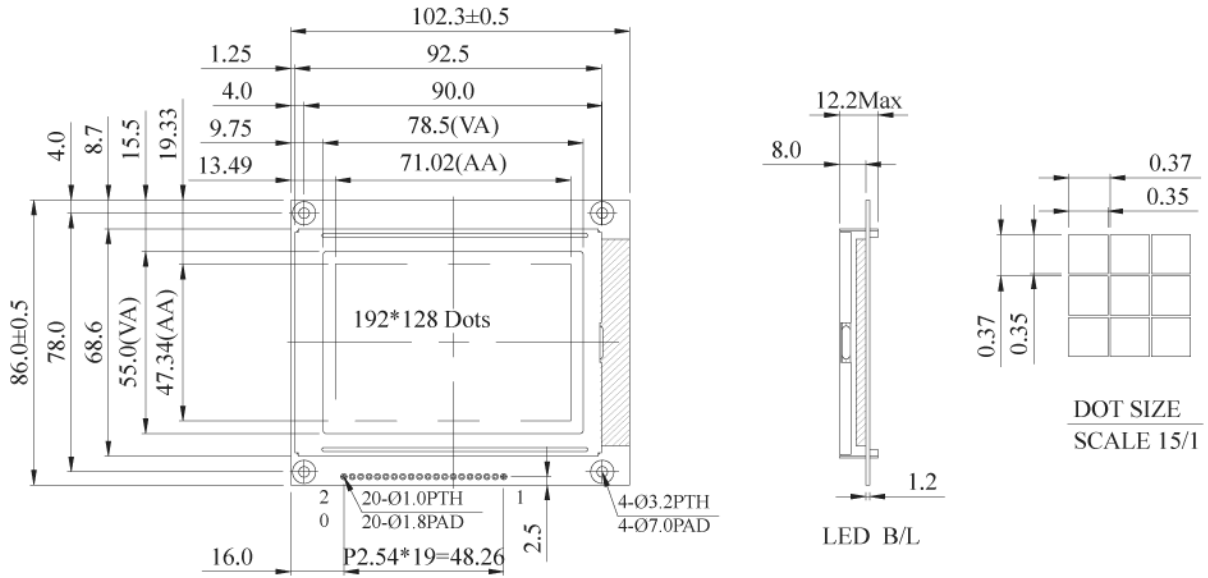

Graphic type

Feature

1. Built-in controller SANYO-(LC7981 or equivalent)
2. 1/128 duty cycle
3. Built-in N.V.

Pin NO.	Symbol	Function
1	Vss	Ground
2	Vdd	Supply voltage for logic
3	Vo	Operating voltage for LCD
4	RS	H: Data , L: Instruction
5	RW	H: read data L: write data
6	E	Enable signal
7	DB0	Data bus line
8	DB1	Data bus line
9	DB2	Data bus line
10	DB3	Data bus line
11	DB4	Data bus line
12	DB5	Data bus line
13	DB6	Data bus line
14	DB7	Data bus line
15	/CS	Chip enable
16	/RST	Reset signal
17	VEE	Negative voltage output
18	NC	No connection
19	A	LED +
20	K	LED -

Mechanical Data

Item	Standard Value	Unit
Module Dimension	102.3x86.0	mm
Viewing Area	75.8x55.0	mm
Dot Size	0.35x0.35	mm
Mounting hole	0.37x0.37	mm

Absolute Maximum Rating

Item	Symbol	Standard Value			Unit
		min.	typ.	max.	
Power Supply	VDD-VSS	4.75	5.0	5.25	V
Input Voltage	VI	0	---	VDD	V

Note: VSS=0 Volt , VDD=5.0 Volt .

Electronical Characteristics

Item	Symbol	Condition	Standard Value			Unit
			min.	typ.	max.	
Input Voltage	VDD	---	4.5	5.0	5.5	V
Supply Current	IDD	VDD=5V	---	1.0	---	mA
Recommended LC Driving Voltage for Normal Temp. Version module	VDD-VO	-20°C	---	---	5.8	V
		25°C	---	4.9	---	
		70°C	4.6	---	---	
CCFL Starting Voltage	VFLS	25°C	---	---	---	Vrms
CCFL Driving Voltage	VFLD	25°C	---	---	---	Vrms
CCFL Driving Current	IFLD	VfQ=450Vrms 30KHZ	---	---	---	mArms
LED Forward Voltage	VF	25°C	3.4	3.5	3.6	V
LED Forward Current	IF	25°C	32	40	60	mA
EL Power Supply Current	IEF	Vel=110VAC/400Hz	---	---	5.0	mA