

WG16080A Graphic 160x80 dots

Dimension drawing

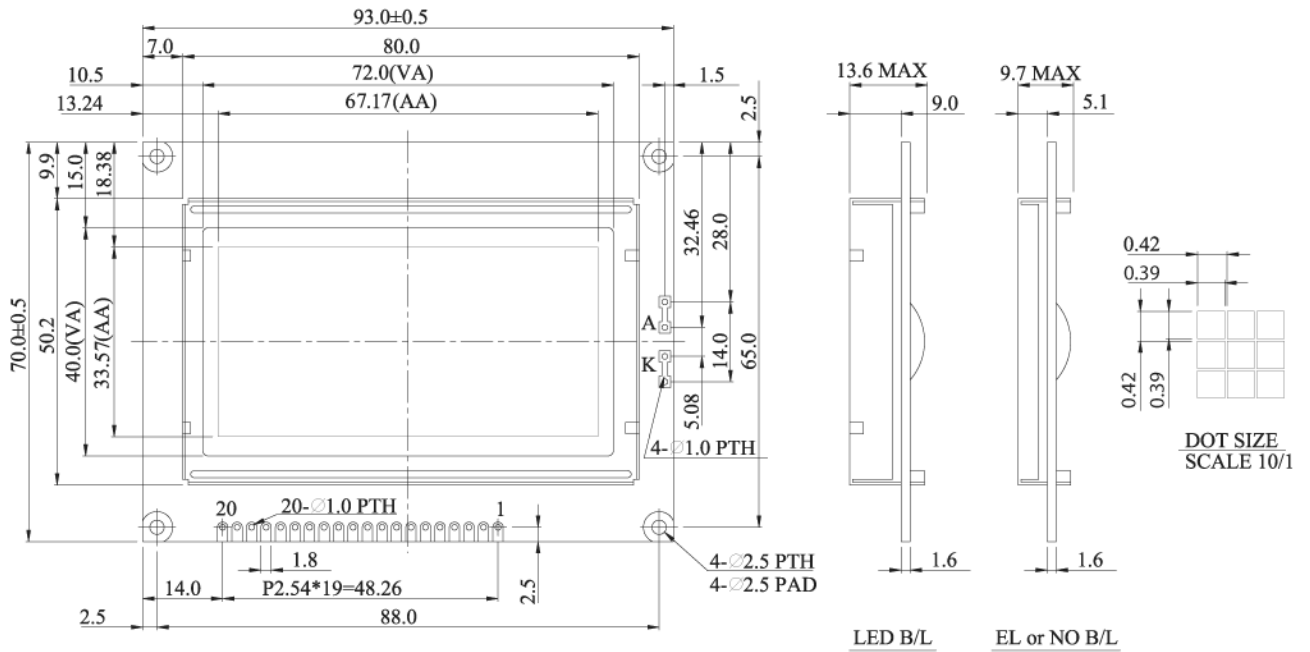

Graphic type

Feature

1. Built-in controller SANYO-(LC7981 or Equivalent)
2. +5V power supply
3. 1/80 duty cycle
4. Built-in N.V.

Mechanical Data

Item	Standard Value	Unit
Module Dimension	93.0x70.0	mm
Viewing Area	72.0x40.0	mm
Mounting hole	88.0x65.0	mm
Dot Pitch	0.52x0.52	mm

Pin NO.	Symbol	Function
1	Vss	GND
2	Vdd	Power supply(+5V)
3	Vo	Contrast Adjustment
4	D/I	H/L Register select signal
5	R/W	H/L Read/Write signal
6	E	H→L Enable signal
7	DB0	DB0 Data bus line
8	DB1	DB1 Data bus line
9	DB2	DB2 Data bus line
10	DB3	DB3 Data bus line
11	DB4	DB4 Data bus line
12	DB5	DB5 Data bus line
13	DB6	DB6 Data bus line
14	DB7	DB7 Data bus line
15	CS	Low:Chip enable
16	DISOFF	Low:Display off signal
17	RST	Reset signal
18	Vee	Negative voltage output
19	A	+4.2V for LED
20	K	0V for LED

Absolute Maximum Rating

Item	Symbol	Standard Value			Unit
		min.	typ.	max.	
Power Supply	VDD-VSS	4.75	5	5.25	V
Input Voltage	VI	0	---	VDD	V

Note : VSS=0 Volt, VDD=5.0 Volt.

Electrical Characteristics

Item	Symbol	Condition	Standard Value			Unit
			min.	typ.	max.	
Input Voltage	VDD	VDD=+5V	4.5	5.0	5.5	V
Supply Current	IDD	VDD=5V	---	0.6	0.8	mA
Recommended LC Driving Voltage for Normal Temp. Version module	VDD-V0	-20°C	---	---	14.5	V
		0°C	---	---	14	
		25°C	---	13.5	---	
		50°C	13.0	---	---	
		70°C	12.5	---	---	
LED Forward Voltage	VF	25°C	---	4.2	4.6	V
LED Forward Current	IF	25°C	---	330	660	mA
EL Power Supply Current	IEL	Vel=110VAC;400Hz	---	---	5.0	mA